

REAR DISCHARGE SPREADER - OPTIONAL FEATURES

REAR DISCHARGE SPREADER - MUCKSPREADER PRODUCT TECHNICAL SPECIFICATION



+ PRECISION SPREADING EQUIPMENT



Compost spreading kit



Apollo or Isobus controller options



Load cells



Sprung drawbar



Ball & spoon type hitch



Air brakes

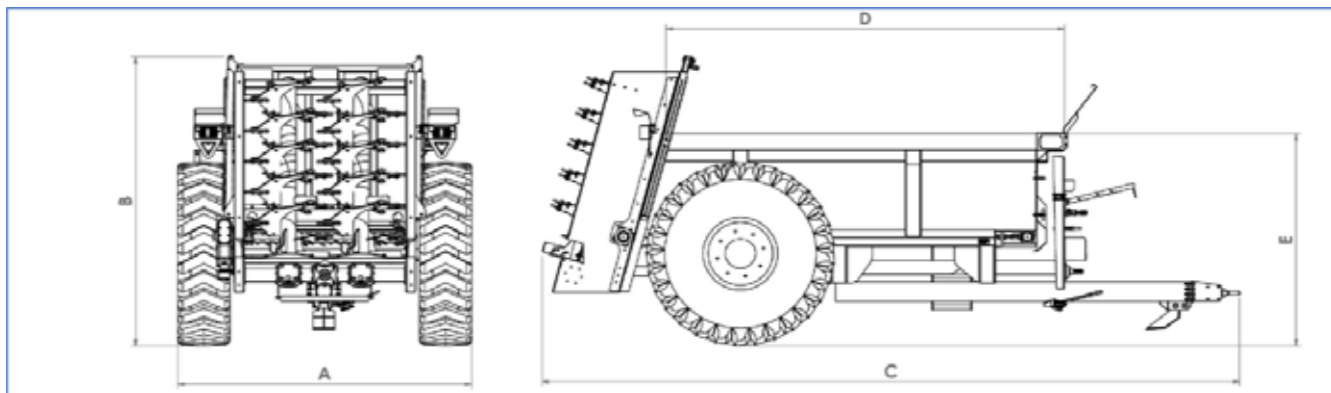

Model	AS 6000 VBS	AS 8000 VBS	AS 10000 VBS**	AS 12000 VBS	AS 19000 VBS, (AS 12000 VBS With Extensions)	AS 26000 VBS
Dim A, (mm)	2500	2500	2900	2925 3380*	3380	2826
Dim B, (mm) Max = door fully open	2800 min	2800 min	3100 min 4450 max	3110 min 4460 max	3110 min 4460 max	3560 min 4910 max
Dim C, (mm)	6000	6300	6555	7975	7975	10480
Dim D, (mm)	3400	3700	3780	4995	4995	7153
Dim E, (mm)	2100	2100	2300	2425	2900	3100
Body Dimensions	3.81m x 1.5m x 0.8m high sides	4.36m x 1.5m x 0.9m high sides	3.8m x 1.5m x 1.25m tapered sides	5.2m x 1.5m x 1.2m high sides, tapered top	5.2m x 1.5m x 1.67m extended	7.2m x 1.82m x 1.456m extended
Cubic Capacity, (m3) [30 degree heap angle]	4.5 level 5.5 Heaped	6.15 level 7.5 HeapedW	7.7 level 10.5 Heaped	8.9 level 11.5 Heaped	14.5 level 19.1 Heaped	20 level 26 Heaped*
Max Carrying Capacity, (mT)	6	8	11	12.5	15.5	26
Unladen Weight, (Kg)	3450	3850	4650	5850	6200	8500
Minimum HP Requirement	80 HP			100 HP		225 HP
Max PTO Input Speed, (RPM)				1000		
Tips - Quantity	44			56		50
Beater Protection Shear Bolt	M10 standard 4.6 grade					
Axle Size & Qty	80 x 80 x 2250mm Single	90 x 90 x 2250mm Single	120 x 120mm x 2350mm Single	150 x 150 x 2350mm Single		150 x 150 x 2350mm Tandem
Floor chain size	16mm grade 80					20mm grade 80
Max Loading Height	6'8"	7'	7'6"	7'11"	9'6"	9'6"
Max Output Rotor Speed	420 rpm					437
Drawbar	150 x 200mm	150 x 200mm	200 x 200mm	200 x 200mm	200 x 200mm	250 x 150mm
Suspension Drawbar	No			Optional		Standard
Wheels	460/85 R34	520/85 R38	580/70 R38	580/70 R38 (800/65 R32)*	800/65 R32	650/55 R26.5
Brake Type & Size	Hydraulic, 300x60mm	Hydraulic, 350x60mm	Hydraulic, 406x120mm			Hydraulic, 420x180mm

\* 40 degree heap angle  
\*\* Will not fit in a Container. European market only



# Rear Discharge Spreader

## REAR DISCHARGE SPREADERS

## REAR DISCHARGE SPREADER - STANDARD FEATURES



The Agrispread range of Rear Discharge Spreaders are capable of handling a wide range of manure types - from semi liquid to well-rotted solid fraction. The dynamically balanced twin vertical beaters, to the rear of the machine, finely chop and distribute the material over a wide spread pattern. The beaters are mechanically driven by a PTO at 1000 RPM through a purpose built gearbox and offer a wider spread pattern.

### Standard Features

- Galvanised floor Lats as standard.
- Heavy duty monocoque body for extra strength.
- 4mm sides with heavy duty reinforcing ribs and 5mm reinforced floor.
- Adjustable flow control valves to alter the rate of discharge.
- 200 x 200 mm heavy duty drawbar with various height options.
- 1500 mm wide back end which houses the purpose built gearbox and rotors.
- The hydraulically controlled variable speed floor is constructed from 16mm high tensile chain and 75mm channels.
- Shotblasted prior to painting
- 2 Coats of Anti-Corrosive two pack primer

and two pack topcoat are applied which is then oven-baked to ensure a quality long lasting finish

- High floatation tyres for broad load distribution to reduce soil compaction.
- Hydraulic brakes are fitted as standard as is a parking brake and stand.
- Hydraulic back door fitted as standard – this helps meter the application rate.
- Auto cover on lights

### Optional Features

- Wide spread package (galvanized)
- Sprung draw bar
- Mudguards
- Commercial axle in lieu of standard (AS6000 & AS8000)
- Commercial axle in lieu of standard with air brakes
- Commercial axle in lieu of standard with air & hydraulic brakes
- Extension sides (painted)
- Extension sides (galvanized)
- Custom colours
- Wide spread package (painted)



Shear bolts



Floor speed controller



Blow off valve



Chain adjustment



Drawbar stand



Automatic fold down lights



Dynamically balanced twin vertical beaters

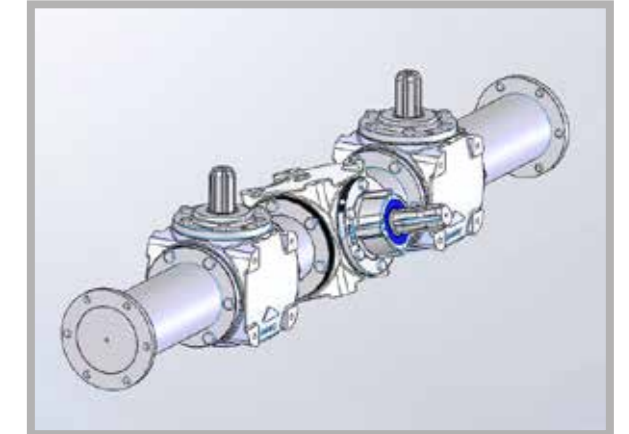

Gear box (One piece design)



16mm high tensile chain



Galvanised floor lats



Galv components

AGRI-SPREAD

Coolnaha, Ballyhaunis,  
Co. Mayo, Ireland.  
+353 9496 31808  
info@agrispread.com  
www.agrispread.com